

Angle Seat Globe Valve, Metal

Construction

The GEMÜ 554 pneumatically operated 2/2-way angle seat globe valve, which can also be used at relatively high temperatures, has a plastic pneumatic piston actuator and PTFE seat providing reliable operation. The valve spindle is sealed by a self-adjusting gland packing providing low maintenance and reliable valve spindle sealing even after a long service life. The wiper ring fitted in front of the gland packing protects it against contamination and damage.

Features

- Substantially reduced installation dimensions when using the body with male threads which can be installed using union nuts
- When using actuated valves in sizes 0 and 1 the gland packing is not subjected to line pressure as the pressure is sealed by the valve seat when closed
- Materials of all medium wetted parts can be selected to suit relevant applications
- Control valves with control cone available
- Versions according to ATEX on request

Advantages

- Various types of valve body connections: Threaded sockets, threaded spigots, butt weld spigots
- Good flow capability
- Extensive range of accessories
- Low weight

Actuator dimensions [mm]				
Actuator size	ø B	M	A2	G
0 + 3	72	M 16x1	70	1/4
1 + 4	96	M 16x1	86	1/4
2	168	M 22x1.5	149	1/4

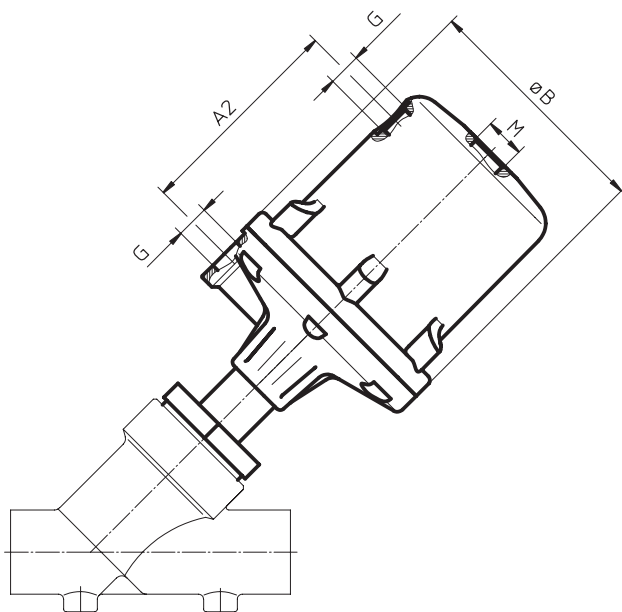

Installation dimensions see page 5.



Technical data

Working medium

Corrosive, inert, gaseous and liquid media which have no negative impact on the physical and chemical properties of the body and seal materials.

Max. perm. pressure of working medium see table

Medium temperature -10°C to 180°C

Max. permissible viscosity 600 mm²/s (cSt)

Other versions for higher viscosities on request

Control medium

Inert gases

Max. perm. temperature of control medium: 60°C

Filling volume	Actuator size 0 and 3:	0.05 dm ³
	Actuator size 1 and 4:	0.125 dm ³
	Actuator size 2:	0.625 dm ³

Ambient conditions

Max. ambient temperature 60°C

Flow direction

See page 4

Nominal size [mm]	Max. operating pressure [bar] control function 1*					Min. control pressure [bar] control function 1					Kv value [m ³ /h]
	Act. size 0 piston ø 50 mm	Act. size 3 piston ø 50 mm	Act. size 1 piston ø 70 mm	Act. size 4 piston ø 70 mm	Act. size 2 piston ø 120 mm	Actuator size 0	Actuator size 3	Actuator size 1	Actuator size 4	Actuator size 2	
10	12.0	10	25.0	10	-	4.8 - 7.0	min. control pressure see diagram max. control pressure 7 bar	5.5 - 7.0	min. control pressure see diagram max. control pressure 7 bar	-	4.5
15	12.0	10	25.0	10	-	4.8 - 7.0		5.5 - 7.0		-	5.4
20	6.0	10	20.0	10	25	4.8 - 7.0		5.5 - 7.0		4 - 7	10.0
25	2.5	10	10.0	10	25	4.8 - 7.0		5.5 - 7.0		4 - 7	15.2
32	-	-	7.0	10	16	-		5.5 - 7.0		4 - 7	23.0
40	-	-	4.5	10	12	-		5.5 - 7.0		4 - 7	41.0
50	-	-	3.0	10	10	-		5.5 - 7.0		5 - 7	71.0
65	-	-	-	-	7	-		-		5 - 7	108.0
80	-	-	-	-	5	-	-	5 - 7	160.0		

* Please note that cast bronze valve bodies, when in pipe systems according to DIN, are only suitable up to PN 16 max., cast stainless steel bodies up to PN 25. All pressures are gauge pressures.

Min. control pressure for actuators 3 and 4 depends on operating pressure.

Kv values determined acc. to IEC 534 standard, body with threaded sockets DIN ISO 228.

The Kv value data refers to control function 1 (NC) and the largest actuator for each nominal size.

Kv values may be different for other combinations. Consult GEMÜ.

Pressure / temperature correlation for angle seat globe valve bodies

Connection code	Material code	Max. allowable pressure (barg) at temperature °C*						
		RT	50	100	150	200	250	300
1, 31, 3B, 9 (up to DN 50)	9	16.0	16.0	16.0	16.0	13.5	-	-
1, 31, 3B, 9 (from DN 65)	9	10.0	10.0	10.0	10.0	8.5	-	-
1, 9, 17, 60	37	25.0	23.7	21.3	19.2	17.7	16.4	15.4
0, 16, 17, 18, 37, 59, 60	34	25.0	24.2	21.2	19.3	17.9	16.8	15.9
80, 82, 86, 88 (up to DN 65)	34	16.0	16.0	16.0	16.0	-	-	-
80, 82, 86, 88 (DN 80)	34	10.0	10.0	10.0	10.0	-	-	-
31, 3B	C1	25.0	24.2	21.2	19.3	17.9	16.8	15.9
13	34	25.0	24.2	21.2	19.3	17.9	16.8	15.9
47	34	19.0	19.0	16.0	14.8	13.6	12.1	10.2

* The valves can be used down to -10°C RT = Room Temperature

Operating pressure/Control pressure characteristics

Actuator size 0 / Normally open (NO) Flow direction: under the seat

Min. control pressure dependent on operating pressure

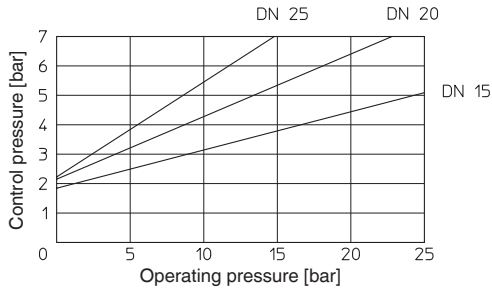

Actuator size 0 / Double acting (DA) Flow direction: under the seat

Min. control pressure dependent on operating pressure

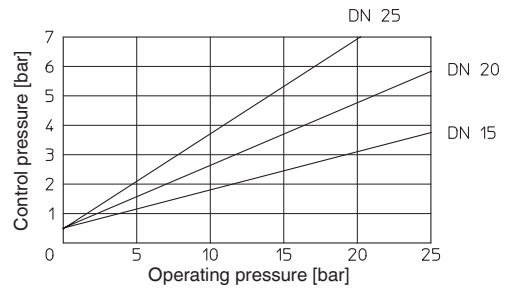

Actuator size 1 / Normally open (NO) Flow direction: under the seat

Min. control pressure dependent on operating pressure

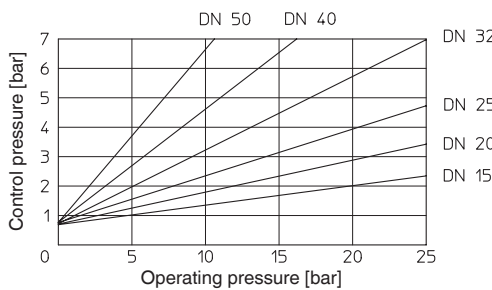

Actuator size 1 / Double acting (DA) Flow direction: under the seat

Min. control pressure dependent on operating pressure

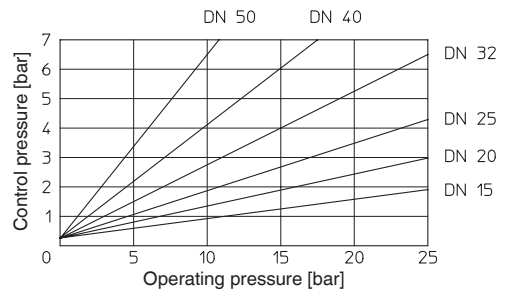

Actuator size 2 / Normally open (NO) Flow direction: under the seat

Min. control pressure dependent on operating pressure

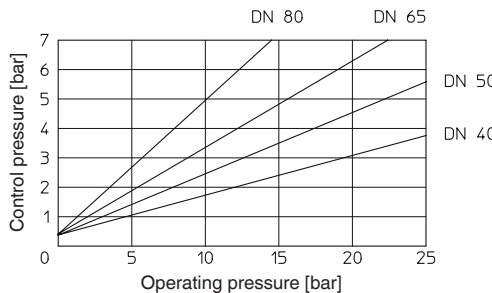

Actuator size 2 / Double acting (DA) Flow direction: under the seat

Min. control pressure dependent on operating pressure

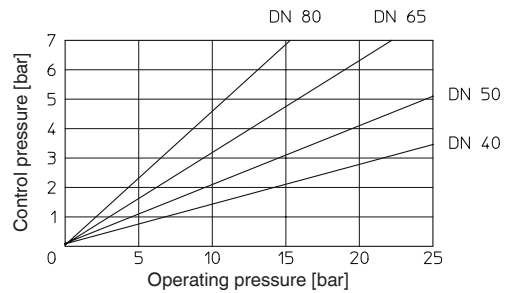

Actuator size 3 / Normally closed (NC) Flow direction: over the seat

Min. control pressure dependent on operating pressure

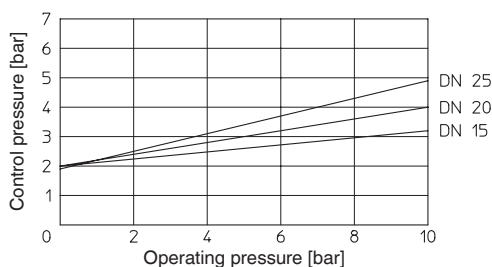

Actuator size 4 / Normally closed (NC) Flow direction: over the seat

Min. control pressure dependent on operating pressure

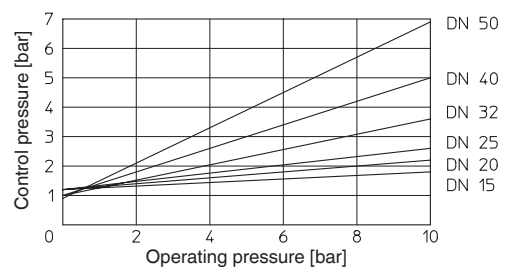

Order data

Body configuration	Code
2/2-way body	D

Seat seal	Code
PTFE	5
PTFE, glass reinforced	5G
Other seat seals on request	

Connection	Code
Butt weld spigots	
Spigots DIN	0
Spigots DIN 11850, series 1	16
Spigots DIN 11850, series 2	17
Spigots DIN 11850, series 3	18
Spigots SMS 3008	37
Spigots ASME BPE	59
Spigots EN ISO 1127	60
Threaded connections	
Threaded sockets DIN ISO 228	1
Threaded sockets BS 21 Rc	3B
Threaded spigots DIN ISO 228	9
Threaded sockets NPT	31
Flanges	
Flanges EN 1092 / PN25 /form B length see body dimensions	13
Flanges ANSI class 125/150 RF length see body dimensions	47
Clamp connections	
Clamps ASME BPE for pipe ASME BPE, short design	80
Clamps DIN 32676 series B for pipe EN ISO 1127, length EN 558, series 1	82
Clamps DIN 32676 series A for pipe DIN 11850, length EN 558, series 1	86
Clamps ASME BPE for pipe ASME BPE, length EN 558, series 1	88

Control function	Code
Normally closed (NC)	1
Normally open (NO)	2
Double acting (DA)	3

Actuator size	Flow	Code
Actuator 0 piston ø 50 mm	under the seat	0*
Actuator 1 piston ø 70 mm	under the seat	1*
Actuator 2 piston ø 120 mm	under the seat	2*
Actuator 3 piston ø 50 mm	over the seat	3**
Actuator 4 piston ø 70 mm	over the seat	4**
* Preferred flow direction with incompressible liquid media to avoid "water hammer"		
** only control function NC		

Valve body material	Code
Rg 5, cast bronze	9
1.4435 (ASTM A 351 CF3M \triangleq 316L), investment casting	34
1.4408, cast stainless steel	37
ASTM A 351 CF3M, investment casting*	C1
* Material equivalency 316L	

GEMÜ 554
Actuators 0, 1, 2



Flow
under the seat

GEMÜ 554
Actuators 3, 4



Flow
over the seat

Order example	554	15	D	1	9	5	1	1
Type	554							
Nominal size		15						
Body configuration (code)			D					
Connection (code)				1				
Valve body material (code)					9			
Seat seal (code)						5		
Control function (code)							1	
Actuator size (code)								1

Installation dimensions [mm]

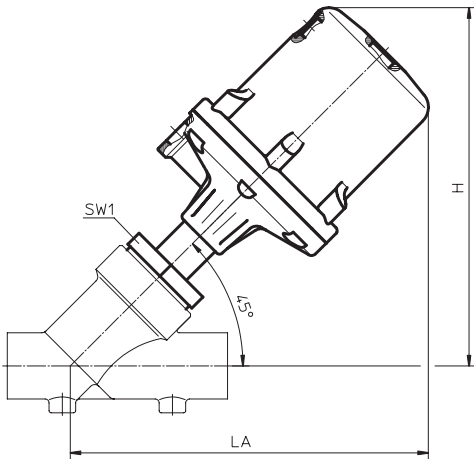

Installation dimensions [mm] / Weight [kg]							
		Actuator size 0 and 3		Actuator size 1 and 4		Actuator size 2	
DN	Wrench size SW1	H/LA	Weight	H/LA	Weight	H/LA	Weight
10	36	152	0.9	179	1.4	-	-
15	36	155	0.9	182	1.4	-	-
20	41	165	1.1	192	1.6	279	-
25	46	165	1.3	192	1.8	279	-
32	55	-	-	200	2.4	287	5.1
40	60	-	-	206	2.7	293	6.0
50	75	-	-	214	3.4	301	6.9
65	75	-	-	-	-	313	8.5
80	75	-	-	-	-	330	10.1

Body dimensions [mm]

Butt weld spigots, connection code 0, 16, 17, 18, 37, 59, 60
Valve body material: 1.4435 (code 34), 1.4408 (code 37)

DN	Material code 34		Material code 37		Connection code															
					0		16		17		18		37		59		60			
					ø d	s	ø d	s	ø d	s	ø d	s	ø d	s	ø d	s	ø d	s	ø d	s
10	105	35.5	-	-	-	-	12	1.0	13	1.5	14	2.0	-	-	-	-	17.2	1.6		
15	105	35.5	100	33	18	1.5	18	1.0	19	1.5	20	2.0	-	-	12.70	1.65	21.3	1.6		
20	120	39.0	108	33	22	1.5	22	1.0	23	1.5	24	2.0	-	-	19.05	1.65	26.9	1.6		
25	125	38.5	112	32	28	1.5	28	1.0	29	1.5	30	2.0	25.0	1.2	25.40	1.65	33.7	2.0		
32	155	48.0	137	39	-	-	34	1.0	35	1.5	36	2.0	-	-	-	-	42.4	2.0		
40	160	47.0	146	40	40	1.5	40	1.0	41	1.5	42	2.0	38.0	1.2	38.10	1.65	48.3	2.0		
50	180	48.0	160	38	52	1.5	52	1.0	53	1.5	54	2.0	51.0	1.2	50.80	1.65	60.3	2.0		
65	-	-	290	96	-	-	-	-	70	2.0	-	-	63.5	1.6	63.50	1.65	76.1	2.0		
80	-	-	310	95	-	-	-	-	85	2.0	-	-	76.1	1.6	76.20	1.65	88.9	2.3		

For materials see overview on last page

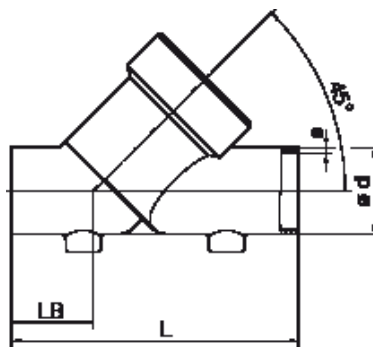

Body dimensions [mm]

Threaded sockets DIN, connection code 1 Valve body material: Cast bronze (code 9), 1.4408 (code 37)

DN	L	LB	G	Material code 9			Material code 37		
				t	SW2		t	SW2	
10	65	16.5	G 3/8	-	-	-	9	27	hexagonal
15	65	17.0	G 1/2	15.0	27	hexagonal	9	25	hexagonal
20	75	18.0	G 3/4	16.3	32	hexagonal	11	31	hexagonal
25	90	24.0	G 1	19.0	41	hexagonal	12	39	hexagonal
32	110	33.0	G 1 1/4	21.4	50	octagonal	14	48	octagonal
40	120	30.0	G 1 1/2	21.4	55	octagonal	14	55	octagonal
50	150	40.0	G 2	25.7	70	octagonal	15	66	octagonal
65	190	46.0	G 2 1/2	24.0	85	octagonal	22	85	octagonal
80	220	50.0	G 3	27.0	100	octagonal	25	100	octagonal

For materials see overview on last page.

Threaded sockets NPT. BS 21 Rc. connection code 31. 3B Valve body material: Cast bronze (code 9), 316L (code C1)

DN	L	LB	SW2	Connection code			
				31		3B	
				G	t	G	t
15	81	24.5	27 6	1/2" NPT	13.6	Rc 1/2	15.0
20	87	24.0	32 6	3/4" NPT	14.0	Rc 3/4	16.3
25	104	31.0	41 6	1" NPT	16.8	Rc 1	19.0
32	122	39.0	50 8	1 1/4" NPT	17.3	Rc 1 1/4	21.4
40	136	38.0	55 8	1 1/2" NPT	17.3	Rc 1 1/2	21.4
50	165	47.5	70 8	2" NPT	17.7	Rc 2	25.7
65	212	57.0	85 8	2 1/2" NPT	23.7	Rc 2 1/2	30.2
80	242	61.0	100 8	3" NPT	25.9	Rc 3	33.3

For materials see overview on last page.

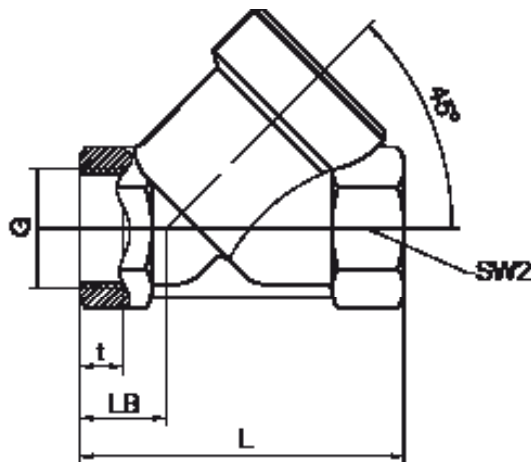

Body dimensions [mm]

Threaded spigots, connection code 9 Valve body material: Cast bronze (code 9), investment casting (code 37)

DN	L	LB	I	G
15	90	25	12	G 3/4
20	110	30	15	G 1
25	118	30	15	G 1 1/4
32	130	38	13	G 1 1/2
40	140	35	13	G 1 3/4
50	175	50	15	G 2 3/8
65	216	52	15	G 3
80	254	64	18	G 3 1/2

For materials see overview on last page.

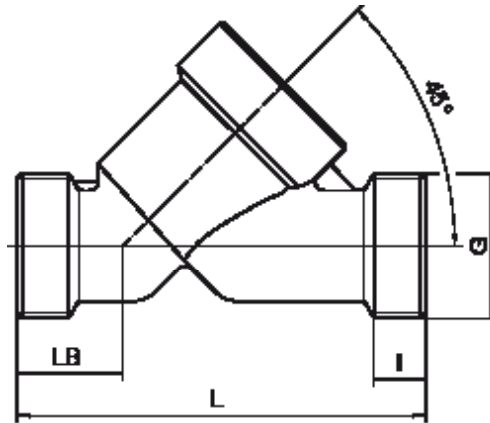

Flanges, connection code 13, 47 Valve body material: 1.4435 (code 34)

DN	FTF	LB	Connection code 13				Connection code 47			
			$\varnothing D$	$\varnothing L$	$\varnothing k$	Number of bolt	$\varnothing D$	$\varnothing L$	$\varnothing k$	Number of bolt
15	210	72	95	14	65	4	89.0	15.7	60.5	4
20	280	78	105	14	75	4	98.6	15.7	69.8	4
25	280	77	115	14	85	4	108.0	15.7	79.2	4
32	310	89	140	18	100	4	117.3	15.7	88.9	4
40	320	91	150	18	110	4	127.0	15.7	98.6	4
50	333	95	165	18	125	4	152.4	19.1	120.7	4

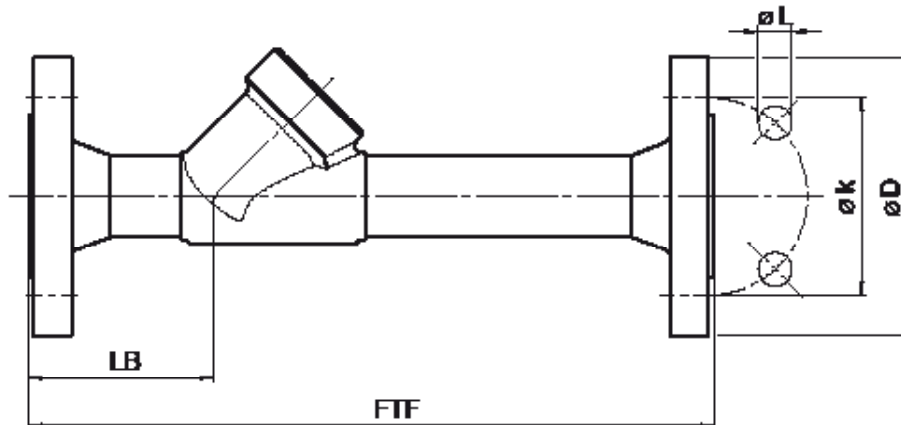

Body dimensions [mm]

Clamp connections, connection code 80, 82, 86, 88
Valve body material: 1.4435 (code 34)

DN	NPS	Connection code											
		LB	LC	82		86		88		80			
				ø d1	ø d3	ø d1	ø d3	ø d1	ø d3	LB	LC	ø d1	ø d3
15	1/2"	35.5	130	18.1	50.5	16	34.0	9.40	25.0	33.5	101.60	9.40	25.0
20	3/4"	39,0	150	23.7	50.5	20	34.0	15.75	25.0	30.0	101.60	15.75	25.0
25	1"	38,5	160	29.7	50.5	26	50.5	22.10	50.5	33.0	114.30	22.10	50.5
32	1 1/4"	48,0	180	38.4	64.0	32	50.5	-	-	-	-	-	-
40	1 1/2"	47,0	200	44.3	64.0	38	50.5	34.80	50.5	37.0	139.70	34.80	50.5
50	2"	48,0	230	56.3	77.5	50	64.0	47.50	64.0	36.5	158.75	47.50	64.0

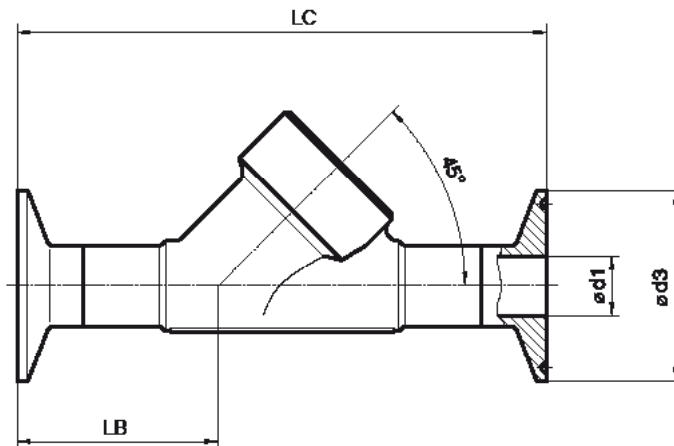

Overview of metal bodies for GEMÜ 554

Connection code	1		3B		9		31		13	47	0	16	17	18	37		59		60		80	82	86	88	
Material code	9	37	9	C1	9	37	9	C1	34	34	34	34	34	37	34	34	37	34	37	34	37	34	34	34	34
DN 10	-	X	-	-	-	-	-	-	-	-	-	X	X	-	X	-	-	-	-	X	-	-	-	-	-
DN 15	X	X	X	X	X	X	X	X	X	X	X	X	X	X	X	-	-	X	-	X	X	X	X	X	X
DN 20	X	X	X	X	X	X	X	X	X	X	X	X	X	X	X	-	-	X	-	X	X	X	X	X	X
DN 25	X	X	X	X	X	X	X	X	X	X	X	X	X	X	X	-	X	-	X	X	X	X	X	X	X
DN 32	X	X	X	-	-	X	X	-	X	X	-	X	X	X	X	-	-	-	-	X	X	-	X	X	-
DN 40	X	X	X	X	X	X	X	X	X	X	X	X	X	X	X	-	X	-	X	X	X	X	X	X	X
DN 50	X	X	X	X	X	X	X	X	X	X	X	X	X	X	X	-	X	-	X	X	X	X	X	X	X
DN 65	X	X	X	-	X	X	X	-	-	-	-	-	-	X	-	-	X	-	X	-	X	-	-	-	-
DN 80	X	X	X	-	X	X	X	-	-	-	-	-	-	X	-	-	X	-	X	-	X	-	-	-	-

For further globe valves, accessories and other products please see our Product Range catalogue and Price List.
 Contact GEMÜ

GEMÜ® VALVES, MEASUREMENT
AND CONTROL SYSTEMS

