

# Diaphragms

Product overview and technical data

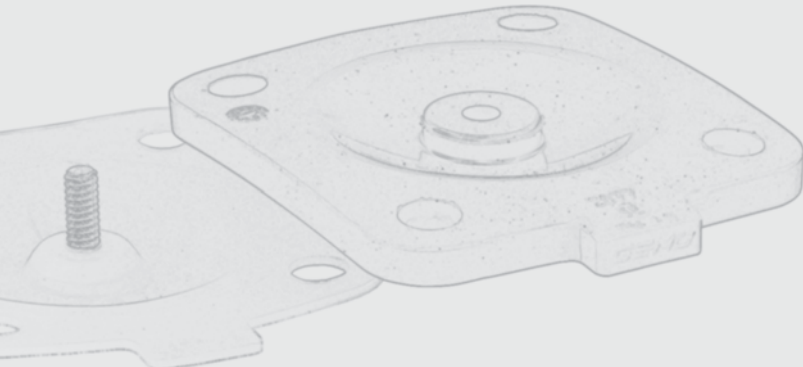



## The original GEMÜ seal system

As a recognised diaphragm valve specialist, GEMÜ are familiar with almost all industrial sectors and applications. We are the leading supplier of stainless steel valves for sterile applications in the pharmaceutical industry, biotechnology industry, as well as the foodstuff and beverage industries. As well as this, our valves also stand for reliability and a high standard of quality in the chemical and processing industries. The diaphragm, a central sealing element in the piping system is of major importance. Only the diaphragm and the valve body are in contact with the medium. At the same time, they also guarantee external hermetic sealing of the pipeline.

### The system is more than the sum of the individual parts

The outstanding characteristics of the diaphragm valve are the result of the perfect interaction of tuned components. These are the valve body, the shut-off diaphragm, the diaphragm fixing, the compressor, as well as the actuator. Our many years of experience and intensive dialogue with plant operators has enabled us to continue optimising the diaphragm valve design and its individual components.

### Diaphragm and valve body are inseparable

GEMÜ valve bodies have a raised circular sealing bead on the inside diameter, in contrast to the valve bodies of other manufacturers. This results in a defined external sealing point. This measure reduces the ring-shaped gap between diaphragm and valve body in the external sealing area. This special feature makes GEMÜ diaphragm valves suitable for sterile applications. We also consider this crucial design and functional characteristic, which was developed by GEMÜ, during the development of our diaphragms. Only this ensures that our customers can rely on the valve as a complete unit.

GEMÜ diaphragms have been developed, tested, and approved for applications with GEMÜ valve bodies. We do not recommend or guarantee the use of diaphragms of other manufacturers with GEMÜ valve bodies due to the unique original GEMÜ seal system.

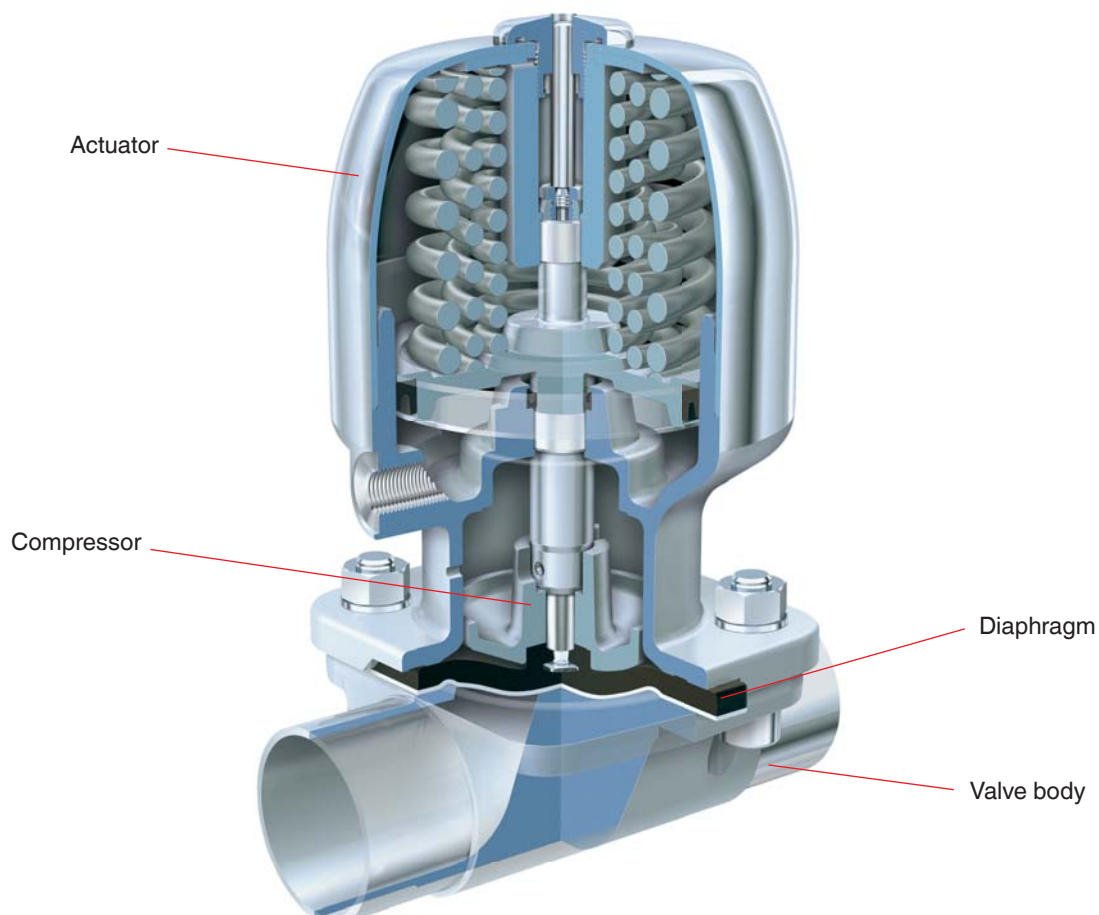

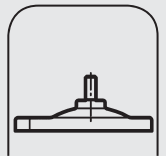

## EHEDG certified seal system

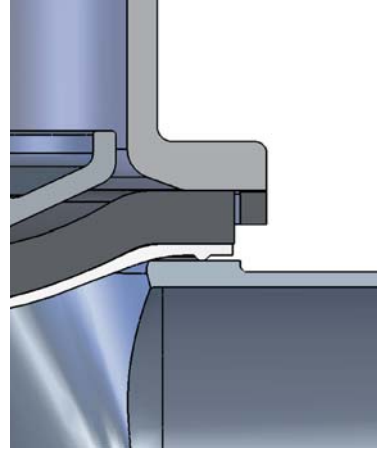
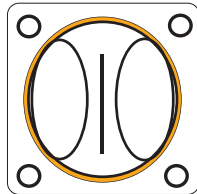
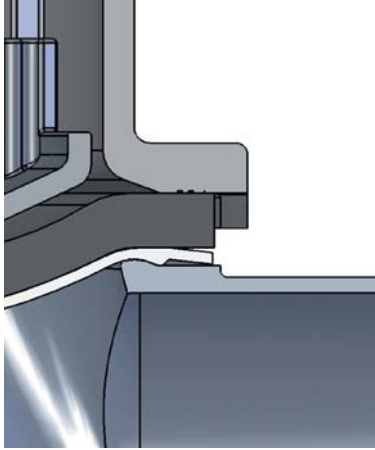

As a leading manufacturer world-wide we had the GEMÜ diaphragm seal system certified in 2002 and were granted the EHEDG certificate.



GEMÜ seal system

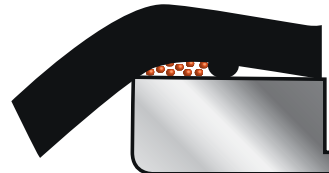

Conventional seal systems

### GEMÜ flexible diaphragm fixing

The diaphragm is uniformly fixed in the compressor by means of a threaded pin. The only exception is the smallest diaphragm size (Diaphragm size 8), which is pushed in with a rubber pin. The uniform fixing method applies both to soft elastomer and PTFE diaphragms. The largest advantage of fixing by means of threaded pin, e.g. in comparison to a bayonet fitting, is that the force transfer is distributed onto the large area of the flanks of the screw thread. This prevents damage to the

mechanical connection between compressor and diaphragm especially under vacuum operating conditions. The uniform fixing of elastomer and PTFE diaphragms permits subsequent replacement of the diaphragms at any time without having to exchange the actuator because its mounting is different like other manufacturers.

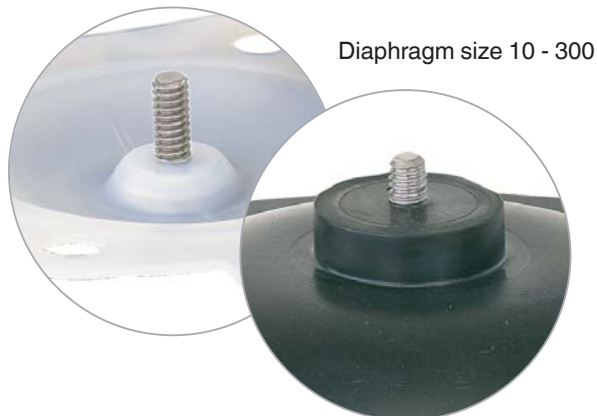

Diaphragm size 10 - 300

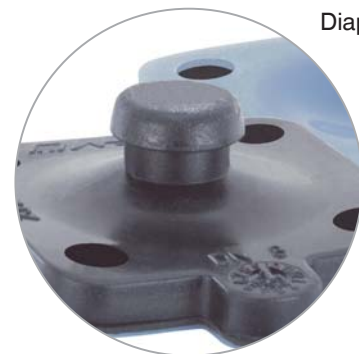

Diaphragm size 8

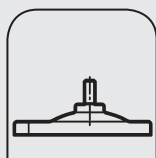

## Selection of diaphragms

Each application must be analysed before the selection of the diaphragm material. Since the most varied operating conditions often prevail within a plant at different locations, it can be necessary to use different valves and materials. In particular, the chemical characteristics and the temperature of the working media often lead to different interactions. The suitability of the

materials used must therefore always be examined individually with regard to the current resistance list or checked by an authorised specialist. Only this procedure guarantees that the application will operate safely and economically for a longer period.

### Diaphragms, which are used predominantly in sterile applications

Diaphragm	Material/Design	MG*	Temperature range [°C]		Mechanical load capacity	Code	
			Liquid media Min.	Max.			
EPDM	Ethylene-propylene-diene rubber	8 - 100	-20	90	150°C max. 60 min.	***	13/3A
EPDM	Ethylene-propylene-diene rubber	8 - 50	-20	90	150°C max. 60 min.	***	16/6A
EPDM	Ethylene-propylene-diene rubber	8 - 100	-20	90	150°C max. 180 min.	**	17
PTFE	Fully laminated PTFE diaphragm with EPDM back	8, 10, 100, 125, 150	-20	90	Constant temperature <sup>1</sup> 150°C	*	52/5A
PTFE	Convex two-piece PTFE diaphragm with loose EPDM back	25, 40, 50, 80	-20	90	Constant temperature <sup>1</sup> 150°C	**	5E

\*\*\*\*\* Highest mechanical load capacity

<sup>1</sup> The diaphragms are applicable as a moisture barrier. The valves concerned must be serviced regularly if steam is applied continuously.

\*MG = Diaphragm size

**Note:**

Since plastics and elastomers are subject to natural aging, we recommend observing the GEMÜ storage conditions for shut-off diaphragms. You thereby guarantee maximum storage and service life of the diaphragms.

The temperature values are indicated irrespective of operating pressure and diaphragm size and apply to water and/or inert gases. The permissible operating pressure decreases with rising temperature and nominal size. Only specially designated diaphragms should be used for steam. The permissible operating pressure results from the steam pressure diagram.

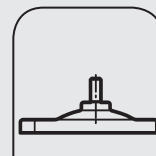

Certificates und approvals*					Compatibility with media	Special features
FDA compliant	USP Class VI	EHEDG	TA Luft	O <sub>2</sub> BAM		
X	X	X	X	X	Very good all-round elastomer, resistant to many acid and alkaline media, demineralised and deionised hot water, inert and many other industrial gases.	Suitable for vacuum, low gas permeability, applicable for steam sterilisation.
X	X	X	X			Higher mechanical stability and service life in comparison to the diaphragm Code 13/3A during steam sterilisation, suitable for vacuum, low gas permeability.
X	X	X				Compound and construction of the diaphragm have been specially optimised for steam applications, clearly improved service life in comparison to the diaphragm Code 16/6A.
X	X	X	X		Resistant to nearly all chemicals, such as strong acids, alkalis and salts, also at higher temperatures, steam, WFI as well as pharmaceuticals. Good resistance to solvents, chlorine, and aromatic hydrocarbons.	Fully laminated diaphragm, can be used in steam. Low gas permeability.
X	X	X	X	X		Convex two-piece diaphragm with loose PTFE face for higher switching cycles, can be used for permanent steam application. Special compounding and production by GEMÜ. Special seal contour for external sealing on the bottom of the diaphragm. Low gas permeability.

\* For details see pages 12-13.



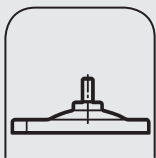

## Selection of diaphragms

### Diaphragms, which are used predominantly in industrial applications

Diaphragm	Material/Design	Diaphragm size	Temperature range [°C]			Mechanical load capacity	Code
			Liquid media Min.	Max.	Steam (Sterilisation)		
CSM	Chlorosulphone-polyethylene, Hypalon	10 - 300	-10	100	not applicable	****	1
NBR	Nitrile rubber, Perbunan	10 - 300	-10	100	not applicable	****	2
FPM	Fluorinated rubber	8 - 300	-10	150	not applicable	****	4/4A
IIR	Butyl	10 - 100	-20	120	not applicable	****	6
CR	Chloroprene rubber, neoprene	10 - 100	-20	100	not applicable	****	8
EPDM	Ethylene-propylene-diene rubber	10 - 300	-20	90	130°C max. 40 min.	****	14
EPDM	Ethylene-propylene-diene rubber	10 - 100, 150	0	80	not applicable	***	18
NR	Natural rubber	10 - 100	-20	60	not applicable	****	15
PTFE	Convex two-piece diaphragm with loose FPM back	25, 40, 50, 80	-20	90	150°C max. 40 min.	**	5F
EPDM	Ethylene-propylene-diene rubber	10 - 100	-20	90	130°C max. 40 min.	***	12

\*\*\*\* Highest mechanical load capacity

**Note:**

Since plastics and elastomers are subject to natural aging, we recommend observing the GEMÜ storage conditions for shut-off diaphragms. You thereby guarantee maximum storage and service life of the diaphragms.

The temperature values are indicated irrespective of operating pressure and diaphragm size and apply to water and/or inert gases. The permissible operating pressure decreases with rising temperature and nominal size. Only specially designated diaphragms should be used for steam. The permissible operating pressure results from the steam pressure diagram.

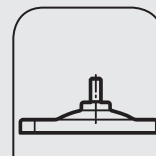

Certificates and approvals*						Compatibility with media	Special features
FDA compliant	USP Class VI	EHEDG	KTW Trinkwasser	TA Luft	O <sub>2</sub> BAM		
						Resistant to different chemicals, inorganic strong acids, alkalis, salt solutions, ozone and weather-resistant. Not resistant to aromatic and chlorinated hydrocarbons.	
				●		Good resistance to mineral oils, greases, and petrol. Not suitable for oxidative media	
				●		Resistant to hydrocarbons and strong acids, aromatic solvents, ozone, chlorine in gas form and chlorinated solvents. Can be used well at high temperatures. Not resistant to ketones and strong alkalis	
						Good resistance to dilute inorganic acids, alkalis and saline solutions, particularly suitable for water and ozone. Unsuitable for oils and hydrocarbons	Suitable for vacuum, low gas permeability, high weathering resistance, very suitable for abrasive media
						Resistant to various chemicals, diluted solutions of inorganic acids, alkalis and salts, ozone-resistant. Not resistant to aromatic hydrocarbons Particularly suitable for corrosive media, diluted acids, alkalis and saline solutions, ozone-resistant, particularly suitable for demineralised and deionised cold/hot water, inert and many other industrial gases. Unsuitable for oils and greases	Weather-resistant and very suitable for abrasive media
						Particularly suitable for corrosive media, diluted acids, alkalis and saline solutions, ozone-resistant, particularly suitable for demineralised and deionised cold/hot water, inert and many other industrial gases. Unsuitable for oils and greases	Weather-resistant, suitable for vacuum, low gas permeability, can be temporarily used for steam
			●			Particularly suitable for corrosive media, diluted acids, alkalis and saline solutions, ozone-resistant, particularly suitable for demineralised and deionised cold/hot water, inert and many other industrial gases. Unsuitable for oils and greases	Weather-resistant, suitable for vacuum, low gas permeability, can be temporarily used for steam
						Resistant to diluted inorganic acids, alkalis, and saline solutions. Unfavourable for oxidising media and oils	High abrasion resistance
●	●	●				Resistant to nearly all chemicals, such as strong acids, alkalis and salts, also at high temperatures, steam, WFI as well as pharmaceuticals. Good resistance to solvents, chlorine, and aromatic hydrocarbons	See diaphragm 5E. FPM back with higher chemical resistance than EPDM back.
●	●	●		●	●	Very good all-round elastomer, resistant to many acid and alkaline media, demineralised and deionised hot water, inert and many other industrial gases.	Suitable for vacuum, low gas permeability, temporarily applicable for steam

\* For details see pages 12-13.



We supply valves and diaphragms, which are free from substances that prevent paint adhesion (e.g. silicone) for applications in the surface finishing/painting industry. The shut-off diaphragms and valves are treated accordingly and packed individually in plastic bags. Furthermore, silicone-free lubricants are used during assembly.

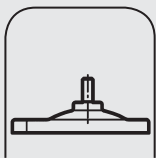

## Soft elastomer diaphragms

Soft elastomer diaphragms consist of rubber mixtures, which are cross-linked (vulcanised) with each other. The diaphragms are provided with different technical features according to the mixture used, vulcanisation temperature and pressure as well as the duration of the cross-linking process. The following statement applies in principle to soft elastomer materials: the higher the temperature load capacity, the lower the service life is in relationship to the mechanical stress. Both the temperature load and the deformability must be implemented optimally for valve diaphragms. For this reason, there are different constructional designs for different applications.

### GEMÜ EPDM Diaphragm Code 17

GEMÜ has developed a new EPDM diaphragm especially for use at high temperatures and with steam for pharmaceutical and biotechnological applications as well as for the food and beverage industries. It is FDA compliant according to title 21 paragraph 177, 2600, certified according to USP Class VI, is free from animal ingredients and ROHS compliant. The compound is peroxide cured and an up to 300% higher service life than diaphragms identical in construction has been verified according to accomplished tests.

- Original GEMÜ diaphragm for sterile diaphragm valves
- Tested on our own steam test rig
- Special compound according to original GEMÜ specifications
- Production and quality control according to high GEMÜ standards
- Certified production takes place within the GEMÜ group

#### Advantages:

- Three times longer service life during steam application
- Higher thermal load capability heat/cold
- Improved sealing due to contour optimisation

#### Technical Data and Features:

- -20°C to +90°C with liquid media
- Max. +150°C steam sterilisation for max. 180 minutes
- Available in diaphragm size 8 – 100, identification code 17 for all sizes
- Suitable for all GEMÜ stainless steel diaphragm valve bodies
- Copolymer made of ethylene and propylene monomers
- Special compounding and production for GEMÜ
- Further improved long-term sealing due to contour optimisation (complies with Pressure Equipment Directive and TA Luft)

Soft elastomer diaphragms are characterised by a high insensitivity in the case of mechanically contaminated working media, e.g. cellular lumps, solid matter or catalytic solid matter. Slurries usually do not affect the function of the valve or the seal on the valve weir. Different materials can be selected according to the operating/sterilisation temperatures and the chemical characteristics of the working media. (EPDM Code 13/3A, 16/6A).

### Service life test results with steam at 150°C

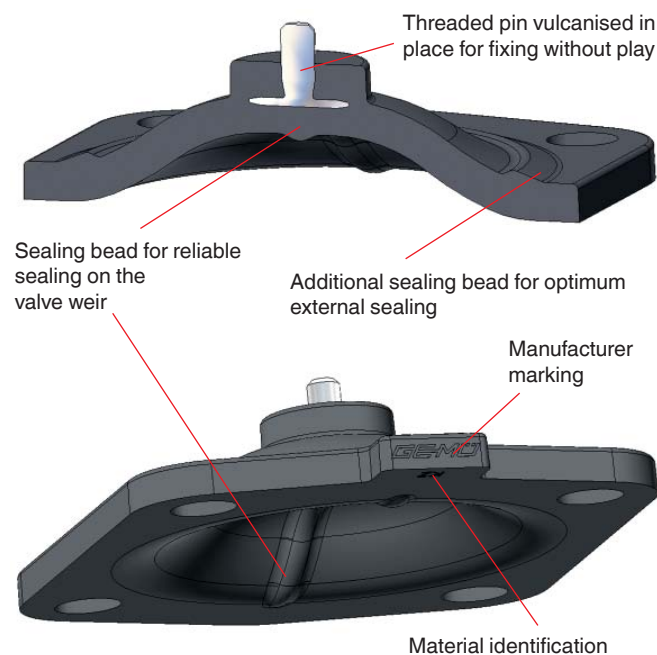
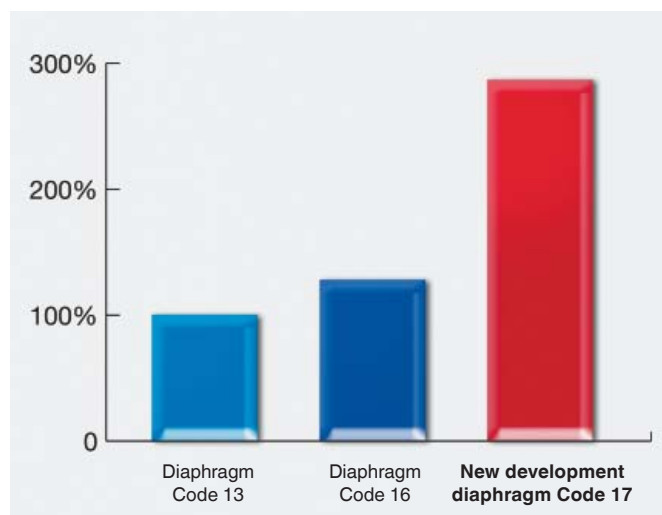

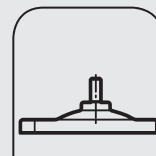

## PTFE diaphragms

Our diaphragms, made of a modified second-generation PTFE, provide maximum chemical resistance. Under steam conditions, PTFE diaphragms age much more slowly than elastomer diaphragms. The relatively rough structure of PTFE materials requires appropriately larger bonding thicknesses, stiffening the diaphragm, than compared to pure elastomer products. This concerns in particular the laminated diaphragms

(Code 52/5A), since the firmly connected materials PTFE and elastomer are mechanically connected by means of the different modules of elasticity. The service life of the diaphragm with regard to the switching frequency is reduced due to the higher rigidity.

### GEMÜ PTFE/EPDM two-piece diaphragm, Code 5E

The solution is the GEMÜ Code 5E flexible PTFE diaphragm. This product unites all the advantages of PTFE with the flexibility of elastomer diaphragms. In order to optimise the entire system again, both the PTFE face as well as the diaphragm back are compounded for GEMÜ and produced by GEMÜ in house.

#### Technical Data and Features:

- -20°C to +90°C continuous operation with liquid media
- max. 150°C in continuous operation with steam
- Available in diaphragm size 25 – 100
- Special compounding and production by GEMÜ
- Special sealing contour for external sealing on the bottom of the diaphragm



Code 5E  
Diaphragm size 25 - 80

### Diaphragm PTFE/EPDM fully laminated, Code 5A/52

The two-piece diaphragm design (5E) is not available in the small diaphragm sizes 8 and 10. Due to the low valve stroke of these sizes there is a clearly reduced mechanical stress in comparison to larger nominal sizes so that the sandwich effect is extremely low. This series is used in order to supplement the diaphragm Code 5E in these two sizes.

The diaphragm Code 52 in the nominal sizes DN 150 - 300 (diaphragm size 150 - 300) is used in the chemical industry, mining, and in many other sectors. The diaphragms are only partially laminated in the middle, in order to reduce the mechanical stress.



Code 5A  
Diaphragm size 8

Code 52  
Diaphragm size 10 - 150

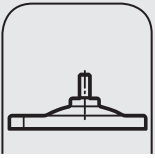

# Diaphragm dimensions

Dimensions															
DN	NPS	MG*	A	B	C	D	ød	e	h	W	α	β	γ	Y	Number of bolt holes
4 - 15	¼" - ½"	8	22	22	31.5	31.5	4.5	4	2.7	-	-	-	-	-	4
10 - 20	⅜" - ¾"	10	39	44	48	53	5.2	5	9	M4 ¼"	-	-	-	-	4
15 - 25	½" - 1"	25	54	46	71.7	66.7	9	6	8	¼"	-	-	-	-	4
32 - 40	1¼" - 1½"	40	70	65	100	90	11.5	7	8	¼"	-	-	-	-	4
50	2"	50	82	78	124	106	13	7	7	¼"	-	-	-	-	4
65	2½"	65	102	95	145	133	14	8	7.5	⅝"	-	-	-	-	4
80	3"	80	127	114	186	156	18	9	8	⅝"	-	-	-	-	4
100	4"	100	194	-	228	-	13	10	9	⅝"	28°	42°	40°	-	8
125	5"	125	222	-	260	-	17	10	10.7	¾"	25°	43.5°	43.5°	-	8
150	6"	150	273	-	305	-	17	11.3	11	¾"	20°	35°	35°	-	10
200	8"	200	381	-	410	-	19	12	22	⅞"	18°	27°	22.5°	22.5°	14
250	10"	250	-	-	-	-	24	12	25	⅞"	22.5°	22.5°	22.5°	22.5°	14
300	12"	300	507	-	563	-	24	14	25	⅞"	18°	24°	24°	24°	14

\* Diaphragm size

The thread of the diaphragm pin "W" corresponds to Whitworth standard.

Exchangeability of diaphragms		
Diaphragm size	Soft elastomer diaphragms (Code)	PTFE diaphragms (Code)
8	3A, 4A, 6A, 17	5A
10 + 100	1, 2, 4, 6, 8, 12, 13, 14, 15, 16*, 17	52
25 - 80	1, 2, 4, 6, 8, 12, 13, 14, 15, 16*, 17	52, 5E, 5F
125 - 300	1, 2, 4, 8, 14	52

\* only diaphragm size 10 - 50

Diaphragm size  
10 - 300

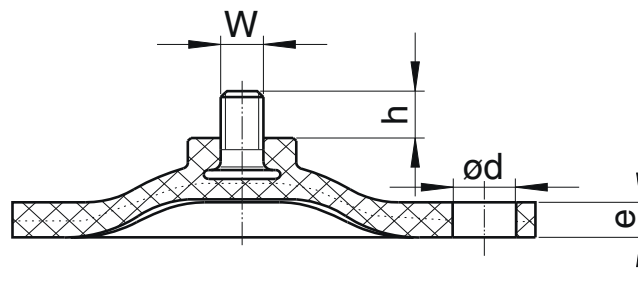

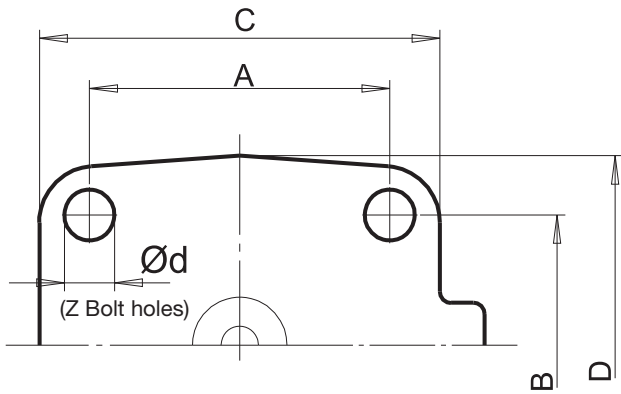
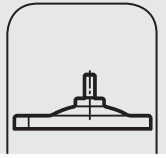

Diaphragm size 8 - 80

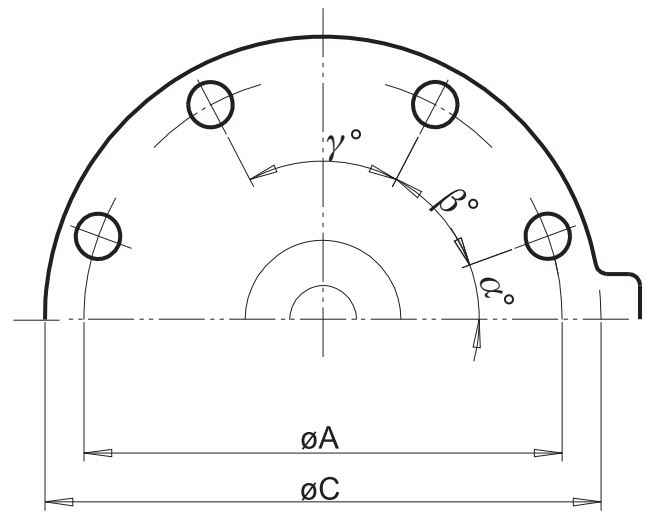

Diaphragm size 100 - 125

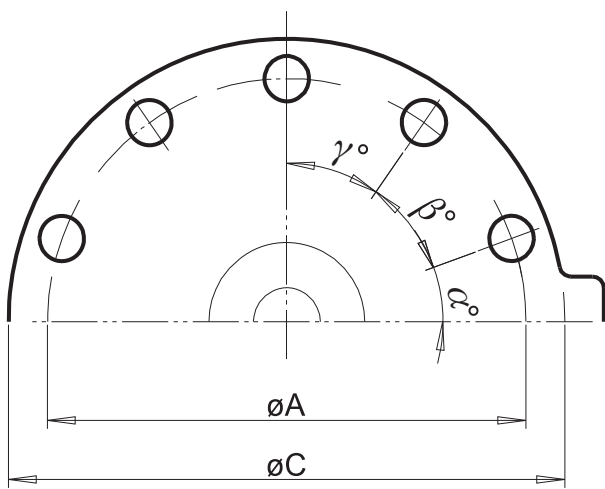

Diaphragm size 150

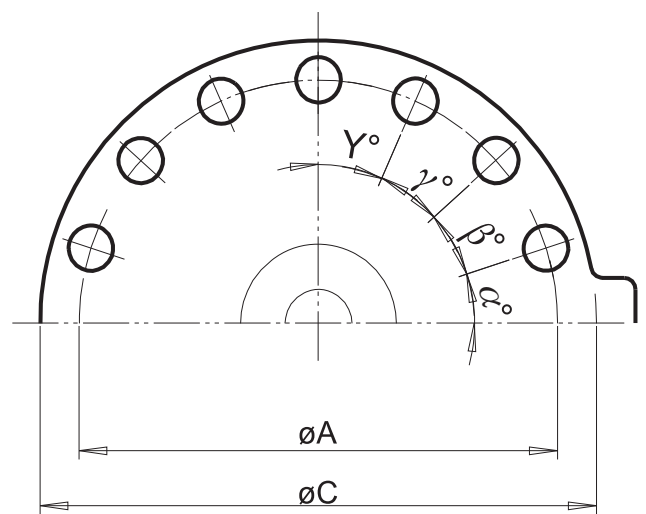

Diaphragm size 200 - 300



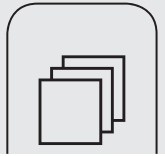

**RoHS**

GEMÜ diaphragms comply with the RoHS Directive 2002/95 EC and the WEEE Directive 2002/96 EC.

**Pressure Equipment Directive**

As all diaphragm valves are pressure bearing components and as the diaphragm is the central sealing element in addition to the valve body, all diaphragms also comply with the European Pressure Equipment Directive 97/23EC Art. 3 § 3. Safety according to the European Pressure Equipment Directive is no longer guaranteed, if original GEMÜ shut-off diaphragms are not installed.

**BAM certificate for use in oxygen applications**

Materials and valves are suitable for use in pure oxygen (O<sub>2</sub>) and comply with the bulletin M934 (BGI 617) with regard to burn-out safety when used with gaseous oxygen.

**GOST certificate**

GEMÜ diaphragm valves are certified according to the Russian GOST and meet the hygienic requirements of the foodstuff industry in Russia.

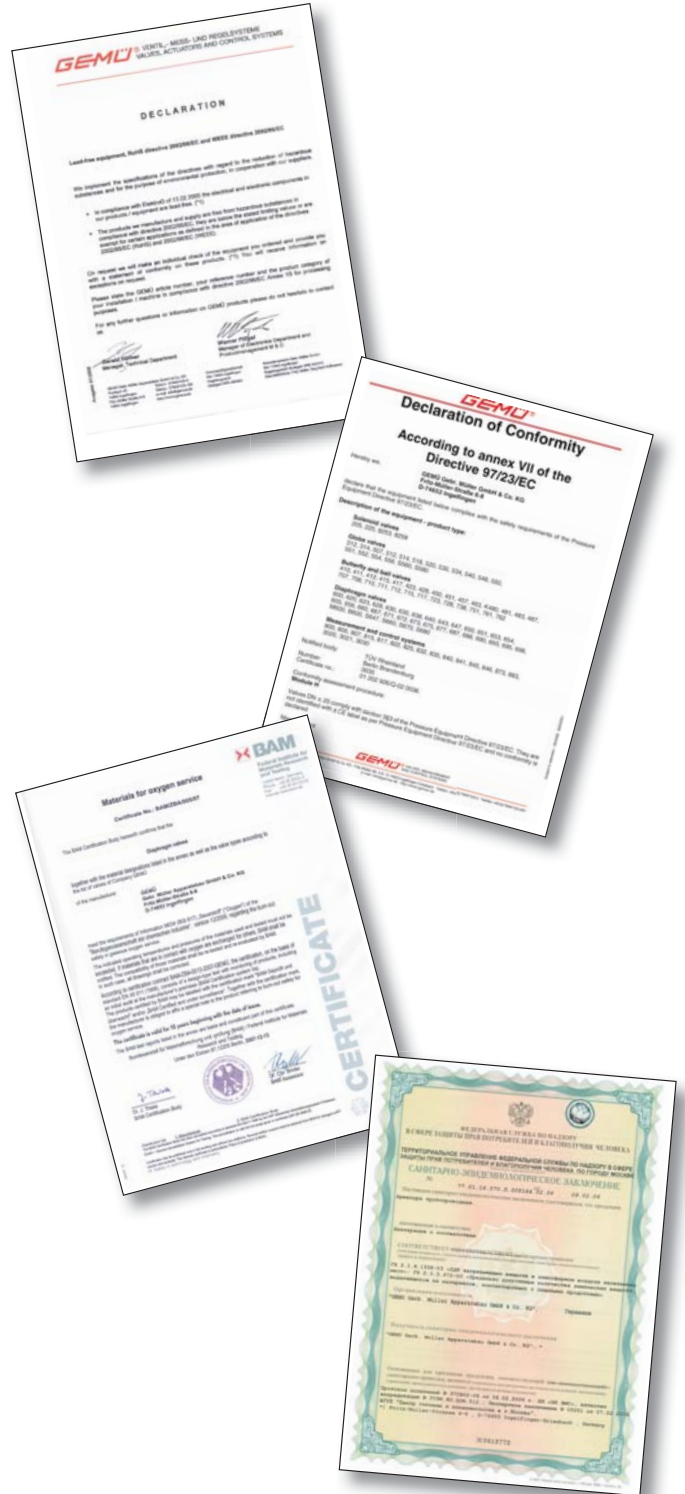



**GEMÜ®**

## Quality Management System

GEMÜ is certified according to DIN EN ISO 9001:2000. This does not only apply to the Ingelfingen site but also to the site in Switzerland, where diaphragm valves and diaphragms are manufactured.

All valves and diaphragms are intensively tested on our own test rigs. They are subjected to several static and dynamic tests because the service life of diaphragms depends on numerous interactions.

Static leakage tests are usually performed on one side and both sides as well as external leak tests (e.g. according to DIN 3230). The maximum operating pressure is usually examined and it is also determined at which operating pressure the first leaks occur. Dynamic tests are continuous stress tests. They are normally carried out at room temperature with a media pressure between 7-9 bar and with steam, depending upon material, between 130° C and 150° C. The limit values are determined for the continuous stress tests depending on the diaphragm material and diaphragm size. The operating pressure for diaphragm valves, which we permit and recommend, is considerably less than the pressure at which the valves start leaking. This means additional safety for your plant. Our shut-off diaphragms sometimes achieve several million switching cycles depending upon application, material, and diaphragm size.

Depending on diaphragm type and material, dynamic vacuum tests (20 mbar absolute) are additionally carried out at ambient pressure. After the diaphragms have overcome these

internal tests without problems, they are released for field tests by selected customers. They are only released for final series production and worldwide marketing after these field tests have been completed successfully.

All compounding for GEMÜ shut-off diaphragms are carried out by well-known manufacturers exclusively for and according to the specifications of GEMÜ. Production is likewise carried out according to the strict GEMÜ quality criteria at selected partners with whom we have a close partnership spanning many years.



*GEMÜ diaphragm production*

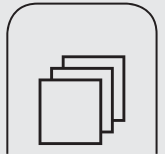

# Product information

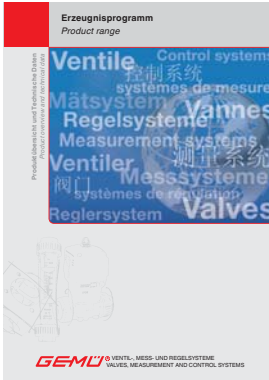

## Product Range

Complete overview of the GEMÜ product range. Provides a short overview of the technical data of the products, their features and application examples.

## Stainless steel diaphragm valves

Complete range of "Valves for sterile applications". Includes an overview of the GEMÜ aseptic valves, available body configurations, connections, nominal sizes and accessories.



## Industrial valves – Metal diaphragm valves

Complete overview of the GEMÜ metal diaphragm valves for industrial applications. Includes an overview of the valves, available body configurations, connections, nominal sizes and accessories.



**GEMÜ**® VALVES, MEASUREMENT  
AND CONTROL SYSTEMS

GEMÜ Gebr. Müller Apparatebau GmbH & Co. KG · Fritz-Müller-Str. 6-8 · D-74653 Ingelfingen-Criesbach · Tel. +49(0)7940/123-0 · Fax +49(0)7940/123-224  
info@gemue.de · www.gemue.de