

Diaphragm Valve, Metal

Construction

The GEMÜ 650 piston actuated 2/2-way diaphragm valve is designed for use in sterile areas of application.

All metallic actuator components are made of stainless steel. Normally closed, Normally open and Double acting control functions are available. The valve is available with two actuator versions: Design D has concealed bolt mounting in the actuator and is only suitable for 2/2-way bodies. Design T is suitable for T valve, Multi-port valve, Tank bottom valve and 2/2-way valve bodies. The valve has an optical position indicator as standard.

Features

- Suitable for inert, corrosive*, liquid and gaseous media
- Valve body and diaphragm available in various materials and designs
- Compact design (ideal when space is at a premium)
- Various connections available
- CIP/SIP cleaning and sterilizing capabilities
- Autoclave capability, dependent on version
- Versions according to ATEX on request

Advantages

- Hermetic separation between medium and actuator
- Optional flow direction
- Optional mounting position
- Design D for the 2/2-way version is mounted by means of female threads in the actuator
- Control air connectors positioned in-line with piping
- Expelled air from spring chamber can optionally be piped to other locations
- Extensive range of accessories, easily retrofitted

*see information on working medium on page 2

Sectional drawing

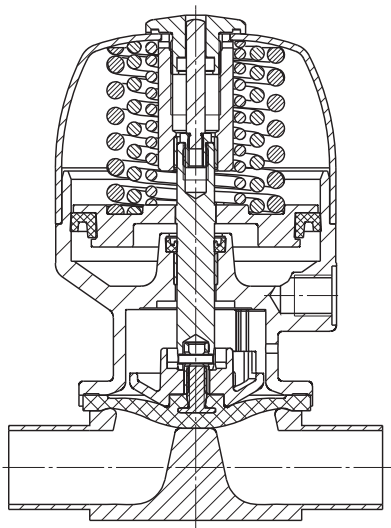

Technical data

Working medium	
Corrosive, inert, gaseous and liquid media which have no negative impact on the physical and chemical properties of the body and diaphragm material.	
The valve will seal in both flow directions up to full operating pressure (gauge pressure).	
Max. operating temperature (dependent on medium wetted materials)	150° C
Ambient conditions	
Max. ambient temperature	60° C

Control medium		
Inert gases		
Max. perm. temperature of control medium		70° C
Actuator size	Piston diameter	Filling volume
OT1	32 mm	0.009 dm ³
OTA	40 mm	0.012 dm ³
1	50 mm	0.031 dm ³
2	80 mm	0.124 dm ³
3	100 mm	0.230 dm ³
4	130 mm	0.493 dm ³

Actuator Code	MG	DN	Operating pressure [bar]		Control pressure [bar]		Weight [g]
			EPDM / FPM	PTFE	C.f. 1	C.f. 2 + 3	
OT1	8	4	0 - 8	0 - 6	5.0 - 7	max. 4.5	300
OT1		6					
OT1		8					
OT1		10					
OT1		15					
OTA	8	4	0 - 10	0 - 6	3.5 - 7	-	320
OTA		6					
OTA		8					
OTA		10					
OTA		15					
1	10	10	0 - 10	0 - 6	4.5 - 7	max. 4.5	900
1		15					
1		20					
2	25	15	0 - 10	0 - 6	5.0 - 7	max. 4.5	2000
2		20					
2		25					
3	40	32	0 - 10	0 - 6	4.5 - 7	max. 5.5	3800
3		40					
4	50	50	0 - 10	0 - 6	4.5 - 7	max. 4.5	8000

All pressures are gauge pressures. Operating pressure values were determined with static operating pressure applied on one side of a closed valve. Sealing at the valve seat and atmospheric sealing is ensured for the given values.
Information on operating pressures applied on both sides and for high purity media on request. MG = diaphragm size

Kv values [m ³ /h]								
MG	DN	DIN Code 0	DIN 11850 Series 1 Code 16	DIN 11850 Series 2 Code 17	DIN 11850 Series 3 Code 18	SMS 3008 Code 37	ASME BPE Code 59	EN ISO 1127 Code 60
8	4	0.5	-	-	-	-	-	-
	6	1.1	-	-	-	-	-	1.2
	8	1.3	-	-	-	-	0.6	2.2
	10	-	2.1	2.1	2.1	-	1.3	-
	15	-	-	-	-	-	2.0	-
10	10	-	2.4	2.4	2.4	-	2.2	3.3
	15	3.3	3.8	3.8	3.8	-	2.2	4.0
	20	-	-	-	-	-	3.8	-
25	15	4.1	4.7	4.7	4.7	-	-	7.4
	20	6.3	7.0	7.0	7.0	-	4.4	13.2
	25	13.9	15.0	15.0	15.0	12.6	12.2	16.2
40	32	25.3	27.0	27.0	27.0	26.2	-	30.0
	40	29.3	30.9	30.9	30.9	30.2	29.5	32.8
50	50	46.5	48.4	48.4	48.4	51.7	50.6	55.2

Kv values determined acc. to IEC 534 standard, inlet pressure 6 bar, Δ p 1 bar, stainless steel valve body and soft elastomer diaphragm.

**Control function 2 + 3
with elastomer diaphragm**

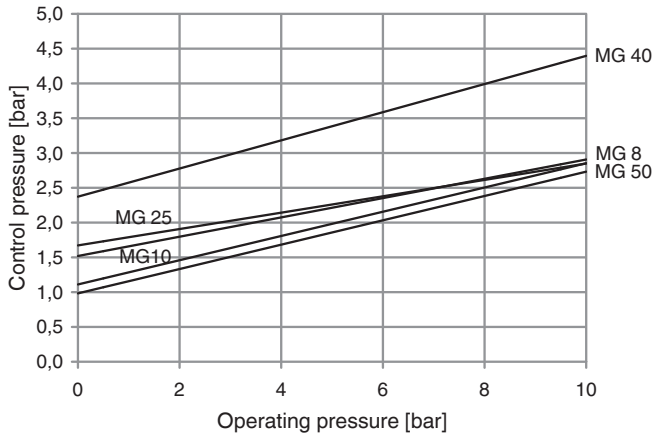

**Control function 2 + 3
with PTFE diaphragm**

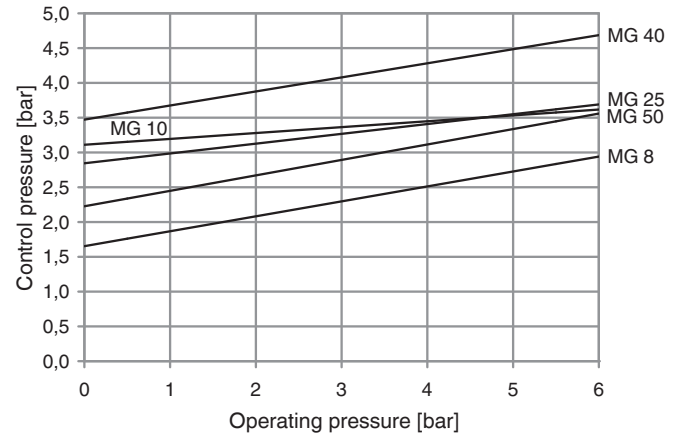

Design up to 10 bar with actuator special function
and forged or block material valve body

Actuator dimensions [mm]							
Actuator dimensions	Diaphragm size	A	A1	A2	ø B	G	M
OT1	8	80.5	28	37.8	42	G 1/8	M12x1
OTA	8	89.5	28	-	47	G 1/8	M12x1
1	10	116.0	37	42.5	61	G 1/4	M16x1
2	25	137.5	38	53.0	90	G 1/4	M16x1
3	40	173.0	53	56.5	114	G 1/4	M16x1
4	50	223.0	52	70.5	144	G 1/4	M16x1

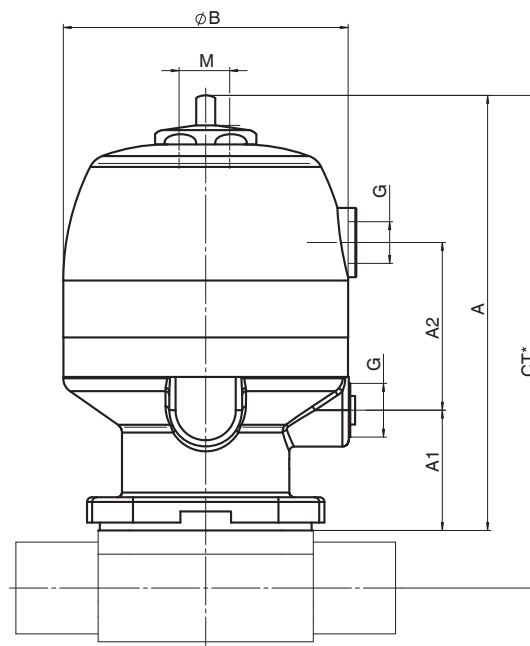

* CT = A + H1 (see body dimensions)

Order data (2/2-way valves)

Body configuration	Code
Tank valve body (actuator version T)	B**
2/2-way body (actuator version D and T)	D
Multi-port design (actuator version T)	M**
T body (actuator version T)	T*
* For dimensions see T Valves brochure	
** Dimensions and versions on request or according to customer requirements	

Connection	Code
Butt weld spigots	
Spigots DIN	0
Spigots DIN 11850, series 1	16
Spigots DIN 11850, series 2	17
Spigots DIN 11850, series 3	18
Spigots DIN 11866, series A	1A
Spigots DIN 11866, series B	1B
Spigots JIS-G 3447	35
Spigots JIS-G 3459	36
Spigots SMS 3008	37
Spigots BS 4825, part 1	55
Spigots ASME BPE	59
Spigots EN ISO 1127	60
Spigots ANSI/ASME B36.19M, Schedule 10s	63
Spigots ANSI/ASME B36.19M, Schedule 40s	65
Threaded connections	
Threaded sockets DIN ISO 228	1
Threaded spigots DIN 11851	6
One side threaded spigot, other side cone spigot and union nut, DIN 11851	62
Aseptic unions on request	
Clamp connections	
Clamps ASME BPE for pipe ASME BPE, short design	80
Clamp DIN 32676 series B for pipe EN ISO 1127, length EN 558, series 7	82
Clamps ASME BPE for pipe ASME BPE, length EN 558, series 7	88
Clamps DIN 32676 series A for pipe DIN 11850, length EN 558, series 7	8A
Clamps SMS 3017 for pipe SMS 3008, length EN 558, series 7	8E
Aseptic clamps on request	
For overview of available valve bodies for GEMÜ 650 see page 8	

Valve body material	Code
1.4435 - BN2 (CF3M) - investment casting Fe<0.5%	32
1.4435 (ASTM A 351 CF3M \triangle 316L), investment casting	34
1.4408, investment casting	37
1.4435 (316L), forged body	40
1.4435 (BN2), forged body Fe<0.5%	42

Diaphragm material	Code
EPDM max. 130°C*	12
EPDM max. 150°C*	13 3A**
EPDM max. 150°C*	16 6A**
EPDM max. 150°C*	17
PTFE/EPDM convex PTFE loose max. 150°C*	5E
PTFE/FPM convex PTFE loose max. 150°C*	5F
PTFE/EPDM PTFE lamin. max. 150°C*	52*** 5A**
* Steam sterilisation temperature / 20 min	
** for diaphragm size 8 *** for diaphragm size 10	
Material complies with FDA requirements, except code 5F	

Control function	Code
Normally closed (NC)	1
Normally open (NO)	2
Double acting (DA) (with opening spring)	3

Actuator size	Code
Actuator size 0 (diaphragm size 8)	0*
Actuator size 1 (diaphragm size 10)	1*
Actuator size 2 (diaphragm size 25)	2*
Actuator size 3 (diaphragm size 40)	3
Actuator size 4 (diaphragm size 50)	4
* Standard autoclave capability	

Design (actuator)	Code
For body configuration D	D
For body configurations B, D, M and T	T
For body configurations B, D, M and T Control air connector at 90° to flow direction	R

Order example	650	50	D	60	40	17	1	4	D	1	1503
Type	650										
Nominal size		50									
Body configuration (code)			D								
Connection (code)				60							
Valve body material (code)					40						
Diaphragm material (code)						17					
Control function (code)							1				
Actuator size (code)								4			
Design (actuator) (code)									D		
Spring set (code)										1	
Surface finish (code see page 5)											1503

Spring set	Code
Standard	1
For higher operating pressure (diaphragm size 8 and 40)	A

Valve body surface finish, internal contour	Code
Ra ≤ 6.3 μm blasted internal/external	1500*
Ra ≤ 6.3 μm electropolished internal/external	1509*
Ra ≤ 0.8 μm mechanically polished internal, blasted external	1502
Ra ≤ 0.8 μm electropolished internal/external	1503
Ra ≤ 0.6 μm mechanically polished internal, blasted external	1507
Ra ≤ 0.6 μm electropolished internal/external	1508
Ra ≤ 0.4 μm mechanically polished internal, blasted external	1536
Ra ≤ 0.4 μm electropolished internal/external	1537
Ra ≤ 0.25 μm mechanically polished internal, blasted external	1527
Ra ≤ 0.25 μm electropolished internal/external	1516

Ra acc. to DIN 4768; at defined reference points
Surface finish data refer to medium wetted surfaces

* only investment cast design

Body dimensions [mm]

Threaded sockets, connection code 1 Valve body material: investment casting (code 34, 37)

Diaphragm size	DN	R	H	H1	t	L	SW2	Number of flats
8	8	G 1/4	19	8.5	12	72	17	2
10	12	G 3/8	23	10.5	13	55	22	2
	15	G 1/2	29	13.5	15	68	24	2
25	15	G 1/2	30	16.0	9	85	27	6
	20	G 3/4	33	17.0	10	85	32	6
	25	G 1	37	17.0	13	110	41	6
40	32	G 1 1/4	50	25.0	16	120	50	8
	40	G 1 1/2	52	25.0	18	140	55	8
50	50	G 2	69	34.0	18	165	70	8

For materials see overview on last page

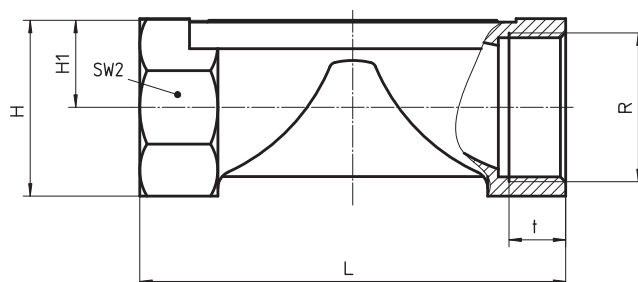

Body dimensions [mm]

Butt weld spigots, connection code 0, 16, 17, 18, 1A, 1B, 60 Valve body material: Investment casting (code 34), forged body (code 40)

									DIN Series 0 Code 0		DIN 11850 Series 1 Code 16		DIN 11850 Series 2 Code 17		DIN 11850 Series 3 Code 18		DIN 11866 Series A Code 1A		DIN 11866 Series B Code 1B		EN ISO 1127 Code 60	
MG	DN	NPS	f*	øg*	L	C	H1*	H1**	ød	s	ød	s	ød	s	ød	s	ød	s	ød	s	ød	s
8	4	-	-	-	72	20	8.5		6	1.0	-	-	-	-	-	-	-	-	-	-	-	-
	6	-	-	-	72	20	8.5		8	1.0	-	-	-	-	-	-	8	1.0	10.2	1.6	10.2	1.6
	8	1/4"	-	-	72	20	8.5		10	1.0	-	-	-	-	-	-	10	1.0	13.5	1.6	13.5	1.6
	10	3/8"	-	-	72	20	8.5		-	-	12	1.0	13	1.5	14	2.0	13	1.5	-	-	-	-
	15	1/2"	-	-	72	20	8.5		-	-	-	-	-	-	-	-	-	-	-	-	-	-
10	10	3/8"	30	13.5	108	25	12.5		-	-	12	1.0	13	1.5	14	2.0	13	1.5	17.2	1.6	17.2	1.6
	15	1/2"	30	13.5	108	25	12.5		18	1.5	18	1.0	19	1.5	20	2.0	19	1.5	21.3	1.6	21.3	1.6
	20	3/4"	30	13.5	108	25	12.5		-	-	-	-	-	-	-	-	-	-	-	-	-	-
25	15	1/2"	40	13.5	120	25	13.0	19.0	18	1.5	18	1.0	19	1.5	20	2.0	19	1.5	21.3	1.6	21.3	1.6
	20	3/4"	40	13.5	120	25	16.0	19.0	22	1.5	22	1.0	23	1.5	24	2.0	23	1.5	26.9	1.6	26.9	1.6
	25	1"	40	13.5	120	25	19.0	19.0	28	1.5	28	1.0	29	1.5	30	2.0	29	1.5	33.7	2.0	33.7	2.0
40	32	1 1/4"	68	13.5	153	25	24.0	26.0	34	1.5	34	1.0	35	1.5	36	2.0	35	1.5	42.4	2.0	42.4	2.0
	40	1 1/2"	75	13.5	153	25	26.0	26.0	40	1.5	40	1.0	41	1.5	42	2.0	41	1.5	48.3	2.0	48.3	2.0
50	50	2"	90	13.5	173	30	32.0	32.0	52	1.5	52	1.0	53	1.5	54	2.0	53	1.5	60.3	2.0	60.3	2.0

* only for investment cast design ** only for forged design MG = diaphragm size
For materials see overview on last page

Butt weld spigots, connection code 35, 36, 37, 55, 59, 63, 65 Valve body material: Investment casting (code 34), forged body (code 40)

									JIS-G 3447 Code 35		JIS-G 3459 Code 36		SMS 3008 Code 37		BS 4825 Code 55		ASME BPE Code 59		ANSI/ASME B36.19M 10s Code 63		ANSI/ASME B36.19M 40s Code 65	
MG	DN	NPS	f*	øg*	L	C	H1*	H1**	ød	s	ød	s	ød	s	ød	s	ød	s	ød	s	ød	s
8	4	-	-	-	72	20	8.5		-	-	-	-	-	-	-	-	-	-	-	-	-	-
	6	-	-	-	72	20	8.5		-	-	10.5	1.20	-	-	-	-	-	-	10.3	1.24	10.3	1.73
	8	1/4"	-	-	72	20	8.5		-	-	13.8	1.65	-	-	6.35	1.2	6.35	0.89	13.7	1.65	13.7	2.24
	10	3/8"	-	-	72	20	8.5		-	-	-	-	-	-	9.53	1.2	9.53	0.89	-	-	-	-
	15	1/2"	-	-	72	20	8.5		-	-	-	-	-	-	12.70	1.2	12.70	1.65	-	-	-	-
10	10	3/8"	30	13.5	108	25	12.5		-	-	17.3	1.65	-	-	9.53	1.2	9.53	0.89	17.1	1.65	17.1	2.31
	15	1/2"	30	13.5	108	25	12.5		-	-	21.7	2.10	-	-	12.70	1.2	12.70	1.65	21.3	2.11	21.3	2.77
	20	3/4"	30	13.5	108	25	12.5		-	-	-	-	-	-	19.05	1.2	19.05	1.65	-	-	-	-
25	15	1/2"	40	13.5	120	25	13.0	19.0	-	-	21.7	2.10	-	-	-	-	-	-	21.3	2.11	21.3	2.77
	20	3/4"	40	13.5	120	25	16.0	19.0	-	-	27.2	2.10	-	-	19.05	1.2	19.05	1.65	26.7	2.11	26.7	2.87
	25	1"	40	13.5	120	25	19.0	19.0	25.4	1.2	34.0	2.80	25.0	1.2	-	-	25.40	1.65	33.4	2.77	33.4	3.38
40	32	1 1/4"	68	13.5	153	25	24.0	26.0	31.8	1.2	42.7	2.80	33.7	1.2	-	-	-	-	42.2	2.77	42.2	3.56
	40	1 1/2"	75	13.5	153	25	26.0	26.0	38.1	1.2	48.6	2.80	38.0	1.2	-	-	38.10	1.65	48.3	2.77	48.3	3.68
50	50	2"	90	13.5	173	30	32.0	32.0	50.8	1.5	60.5	2.80	51.0	1.2	-	-	50.80	1.65	60.3	2.77	60.3	3.91

* only for investment cast design ** only for forged design MG = diaphragm size
For materials see overview on last page

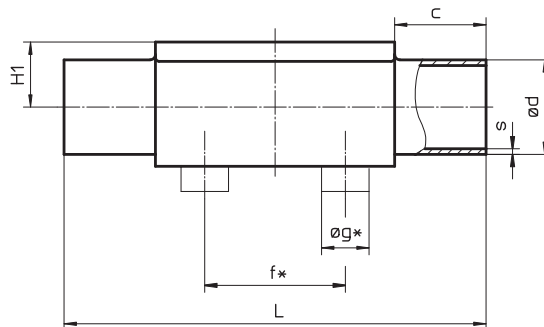

Body dimensions [mm]

Threaded connections, connection code 6, 62 Valve body material: investment casting (code 34), forged body (code 40)

Diaphragm size	DN	H1*	H1**	f*	øg*	ød1*	Thread to DIN 405 R	code 6 L	code 62 L
8	10	8.5	-	-	-	10.0	Rd 28 x 1/8	92	90
10	10	12.5	-	30.0	13.5	10.0	Rd 28 x 1/8	118	116
	15	12.5	-	30.0	13.5	16.0	Rd 34 x 1/8	118	116
25	15	13.0	19	40.0	13.5	16.0	Rd 34 x 1/8	118	116
	20	16.0	19	40.0	13.5	20.0	Rd 44 x 1/6	118	114
	25	19.0	19	40.0	13.5	26.0	Rd 52 x 1/6	128	127
40	32	24.0	26	68.0	13.5	32.0	Rd 58 x 1/6	147	147
	40	26.0	26	75.0	13.5	38.0	Rd 65 x 1/6	160	160
50	50	32.0	32	90.0	13.5	50.0	Rd 78 x 1/6	191	191

* only for investment cast design

** only for forged design

For materials see overview on last page

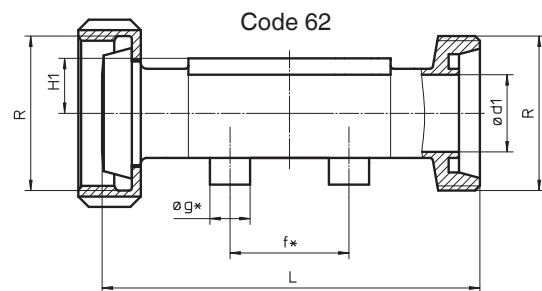
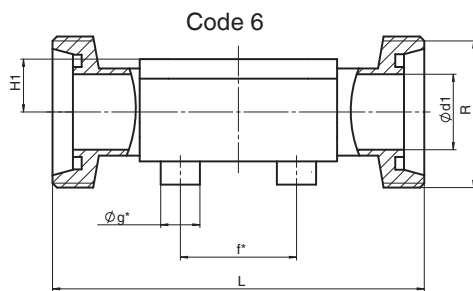

Clamp connections, connection code 80, 82, 88, 8A, 8E Valve body material: forged body (code 40)

				for pipe ASME BPE Code 80			for pipe EN ISO 1127 Code 82			for pipe ASME BPE Code 88			for pipe DIN 11850 Code 8A			for pipe SMS 3008 Code 8E		
MG	DN	NPS	H1	ød1	ød3	L	ød1	ød3	L	ød1	ød3	L	ød1	ød3	L	ød1	ød3	L
8	6	1/8"	8.5	-	-	-	7.00	25.0	63.5	-	-	-	6	25.0	63.5	-	-	-
	8	1/4"	8.5	4.57	25	63.5	10.30	25.0	63.5	-	-	-	8	25.0	63.5	-	-	-
	10	3/8"	8.5	7.75	25	63.5	-	-	-	-	-	-	10	34.0	88.9	-	-	-
	15	1/2"	8.5	9.40	25	63.5	-	-	-	9.40	25.0	108	-	-	-	-	-	-
10	10	3/8"	12.5	-	-	-	14.00	25.0	108.0	-	-	-	10	34.0	108.0	-	-	-
	15	1/2"	12.5	9.40	25	88.9	18.10	50.5	108.0	9.40	25.0	108	16	34.0	108.0	-	-	-
	20	3/4"	12.5	15.75	25	101.6	-	-	-	15.75	25.0	117	-	-	-	-	-	-
25	15	1/2"	19.0	-	-	-	18.10	50.5	108.0	-	-	-	16	34.0	108.0	-	-	-
	20	3/4"	19.0	15.75	25.0	101.6	23.70	50.5	117.0	15.75	25.0	117	20	34.0	117.0	-	-	-
	25	1"	19.0	22.10	50.5	114.3	29.70	50.5	127.0	22.10	50.5	127	26	50.5	127.0	22.60	50.5	127
40	32	1 1/4"	26.0	-	-	-	38.40	64.0	146.0	-	-	-	32	50.5	146.0	31.30	50.5	146
	40	1 1/2"	26.0	34.80	50.5	139.7	44.30	64.0	159.0	34.80	50.5	159	38	50.5	159.0	35.60	50.5	159
50	50	2"	32.0	47.50	64.0	158.8	56.30	77.5	190.0	47.50	64.0	190	50	64.0	190.0	48.60	64.0	190

MG = Diaphragm size

